

UDD IS THE VOLTAGE SOURCE OF SHIELD PIN
 UCC IS THE VOLTAGE SOURCE OF SIMCOM MODULE

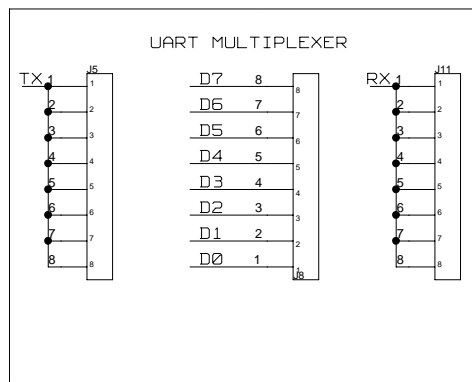

ARDUINO SHIELD PIN MAP

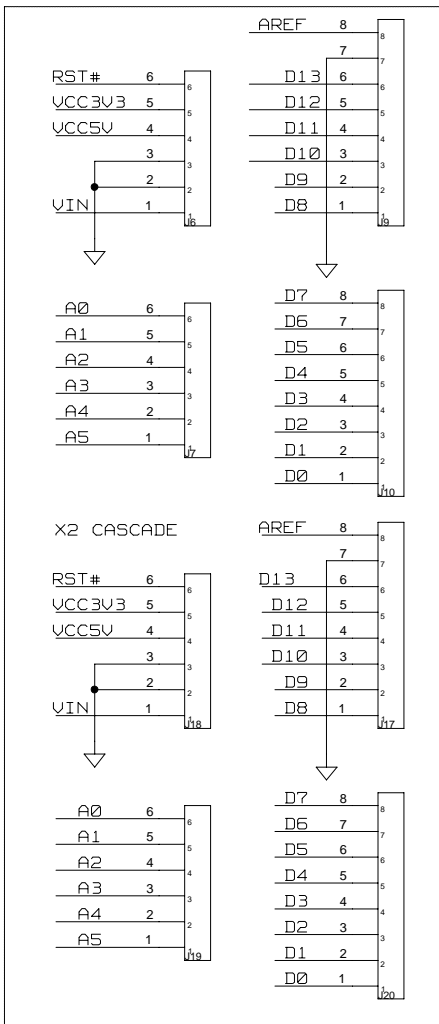

TITLE: _____ DATE: _____

ENGINEER: _____ PAGE: _____

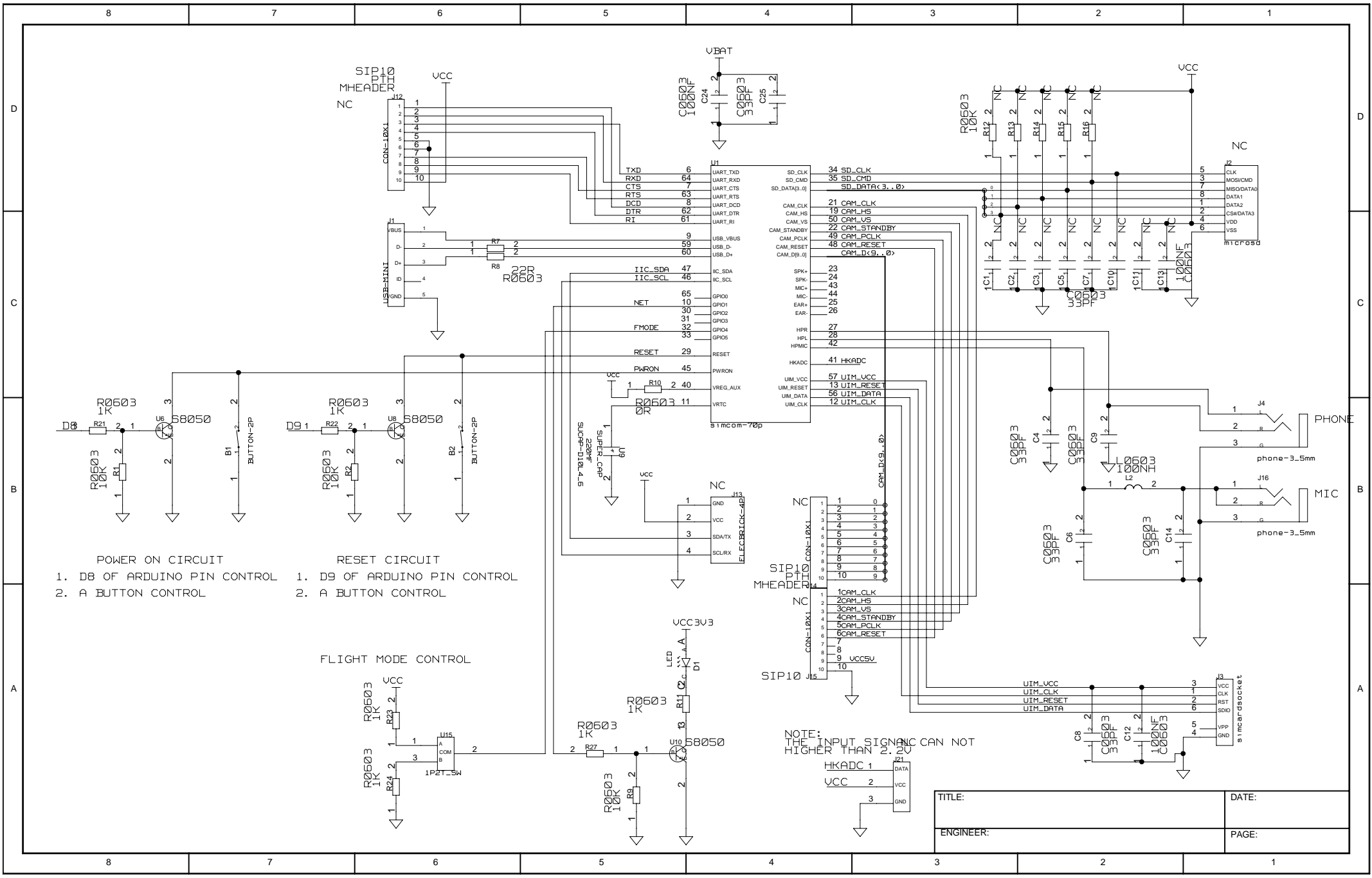

POWER ON CIRCUIT
 1. D8 OF ARDUINO PIN CONTROL
 2. A BUTTON CONTROL

RESET CIRCUIT
 1. D9 OF ARDUINO PIN CONTROL
 2. A BUTTON CONTROL

FLIGHT MODE CONTROL

NOTE: THE INPUT SIGNAL CAN NOT HIGHER THAN 2.2V

TITLE:	DATE:
ENGINEER:	PAGE: